

Main Specifications

Main Specifications		Axle, Tire & Brakes	
Rated Load (kg)	5,000	Rear - Oscillating +/- (°)	±11
Operating Weight with Std Bucket (kg)	17,022	Tire Size, Type & Texture	23.5-25 PR16 Bias
Bucket Capacities (m³)	2.7-4.5	Service Brake	Dry & Caliper, Air to Oil Control
Breakout Force (kN)	168	Parking Brake	Drum Type Shoe Brake
Max. Drawbar Pull Force (kN)	171	Engine	
Service Refill Capacities		Engine Model	WD10G
Fuel Tank (L)	260	Emission	T2/ Stage2
Hydraulic Tank (L)	165	Rated Speed (r/min)	2,000
Engine Lubricating Oil (L)	21	Rated Gross Power (kW)	162
Transmission Oil (L)	53	Displacement (L)	9.7
Transmission		Implement Hydraulic System	
Maker & Type	Tr200	Implement Hydraulic System Type	Twin Pump Flow Merging
Transmission Gear	F4/R4		Hydraulic System
Torque Converter Type	Single Stage, 3 Elements	Hydraulic Cycle Time (s)	9.3
Max Speed (km/hr)	39	Raise (s)	5.1
		System Pressure (MPa)	17

Optional Features

High Lift Arm	QC	3 Spool
U Arm	Pallet Fork	Spark Arrester
Sand Type Tire	Log Gripper	Cummins Engine
GP Bucket	Pipe Gripper	Radial Tire
Rock Bucket	Snow Blade	Oil Bath Air Filter
Coal Bucket	Product Link	Brake Air Drier
Side Dump Bucket		

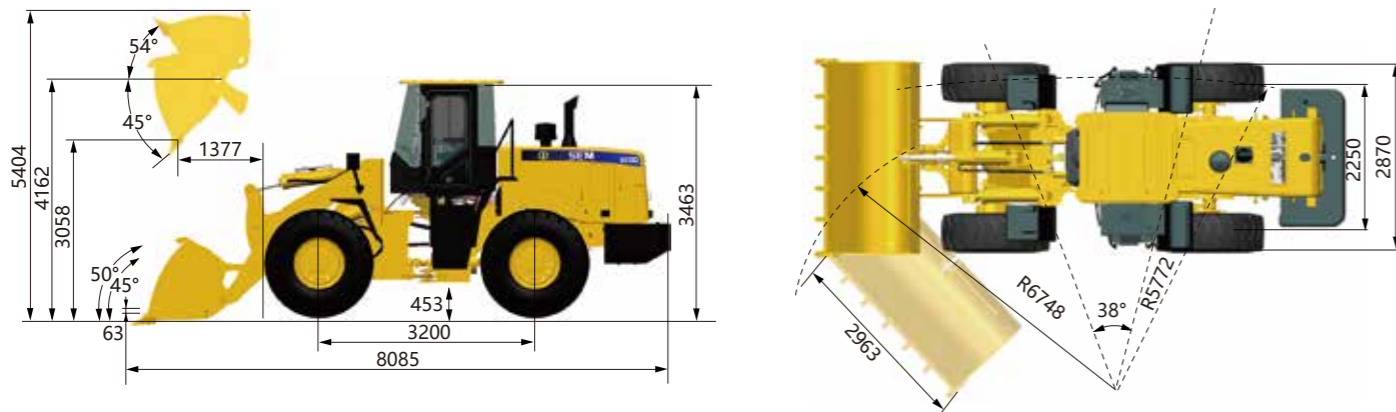

► Note: the above dimensions are based on the standard configuration.

SEM655D Wheel Loader



SEM655D

Product Advantage

- High Productivity
- Best-in-class Reliability and Durability
- Excellent Fuel Economy
- Outstanding Operator Comfort

Caterpillar (Qingzhou) Ltd. Address: No.12999 Nanhuan Road,Caterpillar Industrial Park, Qingzhou City,Shandong Province, Zip Code: 262500 P.R.China

© Materials and specifications are subject to change without notice. Featured machines in photos may include optional equipment. See your SEM dealer for available options.

© 2020 Caterpillar (Qingzhou) Ltd. All Rights Reserved. SEM Machinery, SEM, their respective logos, trade dress as well as corporate and product identity used herein, are trademarks of Caterpillar (Qingzhou) Ltd. and may not be used without permission.

Version: January 2020 - EAEU Region

Website

<http://www.semmachinery.com>



A Caterpillar Brand